

Chicago Plumber Licensure Examination Information

This candidate guide should help you prepare for the Chicago plumber licensure examination. Part I contains general information about testing procedures. Part II outlines the content of the examination and recommends study materials. Part III includes sample questions to help you prepare for the test.

Part I General Information

PURPOSE OF THE EXAMINATIONS

This examination is required for professional licensure of plumbers in the City of Chicago. You must pass this test to be licensed.

TEST VALIDITY & TEST LENGTH

The test is timed to be three hours in length. All test questions have been subjected to strict psychometric controls and reflect standards and practices validated by plumbers who are licensed in the City of Chicago.

STUDY MATERIALS

Study materials for this examination are described in Part II of this candidate guide. These sources may be purchased directly from the publishers, from Internet bookstores such as Amazon.com or Barnes and Noble (bn.com).

REFERENCES & CALCULATORS

References that may be required to answer questions on the test will be provided with the examination. *No calculators or printed materials other than those provided at the test site may be used during the test.*

MISSING AN EXAMINATION

There are no "make-up" examinations. You may re-register for the next examination date. THERE ARE NO REFUNDS.

SUCCESS/ LICENSURE

Candidates who score 70 or higher will receive a PASS notice and an application for licensure.

FAILURE

Candidates who score below 70 will receive a FAILURE notice and an application for re-examination. Candidates are encouraged to retake the examination; many candidates who initially fail such an exam pass on subsequent attempts.

Part II Test Content and Recommended Study Materials

Plumbers must demonstrate that they are familiar with safe practices and procedures in their profession. Content areas and their relative importance in this test are outlined below. Relevant sections of the *2003 Chicago Plumbing Code* are noted. Current editions of the *Chicago Building Code* also provide this information.

- I. Plumbing Theory, Practices & Job safety 20% of Examination**
Public health, Plumbing Math & Principles, Planning, Safety & OSHA Requirements, Tools & Equipment, Basic Electricity

- II. Code Requirements for Plumbers & Contractors 2% of Examination**
Chapter 4-332

- III. Plumbing Systems 44% of Examination**
Chapter 18-29
 - Article I Administration
 - Article II Definitions
 - Article III General Regulations
 - Article IV Fixtures, Faucets & Fixture Fittings
 - Article V Water Heaters
 - Article VI Water Supply & Distribution
 - Article VII Sanitary Drainage
 - Article VIII Indirect/Special Waste
 - Article IX Vents
 - Article X Traps, Separators and Interceptors
 - Article XI Storm Drainage
 - Article XII Swimming Pools

- IV. Rehabilitation Requirements 5% of Examination**
Chapter 13-200
 - 420 Provisions for Buildings being Remodeled
 - 460 Plumbing Requirements

- V. Drawings, Charts & Plans 8% of Examination**
Reading Blueprints, Locating Fixtures, Completing Building Plans to Code

- VI. Cutting & Assembling Plumbing System Components 12% of Examination**
Water Flow & Connection Requirements
Materials, Sizing & Drainage Requirements
Using Copper, Steel, Cast Iron, Plastic & Acid-Resistant Materials

- VII. Troubleshooting, Maintenance & Repairs 10% of Examination**
Repairing Fixtures & Appliances, Waste-Water Systems, Water Distribution Systems, Drainage & Vent systems

Recommended Study Materials

All questions in this examination are based on information provided in the following sources. Therefore, all candidates should become as familiar as possible with each of these references in preparation for this examination. Some information from these references that may be required to answer questions on the test will be provided with the examination. **However, no calculators or printed materials other than those provided at the test site may be used during the test.**

Most publishers will accept telephone orders to be charged to a VISA, Mastercard or American Express account. These references also may be available from Internet bookstores such as Amazon.com or Barnes and Noble (bn.com).

1. 2006 *Chicago Plumbing Code*
(Also available in current edition of *Chicago Building Code*; see content outline to identify relevant sections)
Publisher Index Publishing Company Phone: (312) 644-7800
415 North State Street, Chicago, IL 60610
Website <http://www.lawbulletin.com>
2. Blankenbaker, E. Keith. *Modern Plumbing, 6th Edition* (2005).
Publisher Goodheart-Willcox Company, Inc. Phone: (708) 687-5000
18604 West Creek Drive, Tinley Park, IL 60477-6243
Website <http://www.goodheartwillcox.com>
3. Ripka, L.V., *Plumbing Design and Installation, 3rd Ed.* (2006).
Publisher: American Technical Publishers Phone: (708) 957-1100
1155 West 175th Street, Homewood, IL 60430
Website <http://www.americantech.org>
4. Smith, Lee, Guest, J. Russell, D'Arcangelo, Bartholomew, & D'Arcangelo, Benedict, *Mathematics for Plumbers and Pipefitters, 7th Ed.*, (2008) or 6th Edition, (2004).
Publisher: Delmar Publishing Company Phone: (800) 347-7707
Website: <http://www.delmar.com>
5. Guest, J. Russell, D'Arcangelo, Bartholomew, & D'Arcangelo, Benedict, *Blueprint Reading and Drafting for Plumbers, 2nd Ed*, (2009) Available July 2008.
Publisher: Delmar Publishing Company Phone: (800) 347-7707
Website: <http://www.delmar.com>
6. McConnell, Charles N., *Audel Plumbers Pocket Manual, 10th Edition* (2004)
Publisher: Macmillan Publishing Company Phone: (800) 755-7672
273 Polly Drummond Road, Newark, DE 19711

Part III Sample Test

All questions on these examinations are multiple choice with one correct answer and three incorrect choices. **For this sample test only, correct answers and references are provided at the end of this section to help you prepare for is examination.**

1. Which term refers to the point at which material removed from a trench will stay without sliding back into the trench?
 - A. Excavation
 - B. Trench shield
 - C. Angle of repose
 - D. Trench shoring

2. How many gallons of water are required to fill 2500 feet of a 6-inch water main?
 - A. 306
 - B. 2447
 - C. 2255
 - D. 3670

3. Which of these is appropriate for use on fires involving flammable liquids such as gasoline, grease and oil?
 - A. Class A fire extinguishers marked with a green triangle
 - B. Class B fire extinguishers marked with a red square
 - C. Class C fire extinguishers marked with a blue circle
 - D. Class D fire extinguishers marked with a yellow star

4. What does the *Chicago Plumbing Code* specify prior to a service pipe inspection?
 - A. The entire service pipe must be left accessible until after the inspection.
 - B. The service pipe must be left exposed only within five feet of each end.
 - C. The service pipe trench should be filled with sand and compacted with water.
 - D. The service pipe must be supported by compacted sand prior to the inspection.

5. What does the *Chicago Plumbing Code* specify for underground piping with solder joints?
 - A. Silver brazing alloys
 - B. 95/5 tin-antimony solder
 - C. Any solder with less than 8% lead content
 - D. Any solder with lead content equal to or less than 0.2%

6. Which of these does the *Chicago Plumbing Code* define as a minor repair?
 - A. Replacing a broken house drain
 - B. Removing obstructions from soil and sewer pipes
 - C. Reinstallation of fixtures during a remodeling project
 - D. Installation of new fixtures during a remodeling project

7. What does the *Chicago Plumbing Code* specify as the depth of a sump or receiving tank?
 - A. A minimum of 30 inches
 - B. A maximum of 30 inches
 - C. A minimum of 36 inches
 - D. A maximum of 42 inches

8. What does the *Chicago Plumbing Code* specify as the maximum horizontal length between a trap and its vent?
 - A. 18"
 - B. 24"
 - C. 30"
 - D. 60"

9. What do *Chicago Plumbing Code* specifications require for the grease retention capacity of a grease interceptor or a grease trap?
 - A. Capacity in pounds of grease retained must be twice the flow rate in gpm for the sink or receptor served.
 - B. Capacity in pounds of grease retained must equal the flow rate in gpm from the sink or receptor served.
 - C. At least 75% of the grease received must be retained.
 - D. At least 98% of the grease received must be retained.

10. What does the *Chicago Plumbing Code* specify for handicapped accessibility when doors are being replaced in a remodeled residential building that must meet the Rehabilitation Code?

- A. Any door that is replaced must be at least 32" wide.
- B. Any door that is replaced must be at least 30" wide.
- C. Doors to toilet rooms must be at least 32" wide.
- D. Doors to toilet rooms must be at least 30" wide.

11. Who determines what information is in rough-in sheets?

- A. The architect
- B. The building contractor
- C. The plumbing contractor
- D. The fixture manufacturer

12. Which of these is the architectural symbol for a soldered sanitary T?

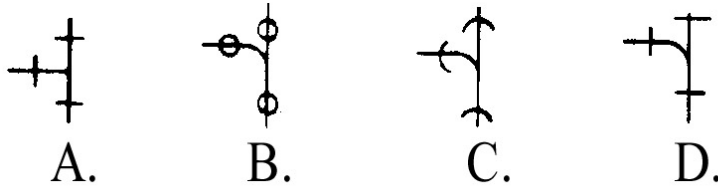

13. What is the total pitch on a 75' long drain line that is installed at a grade of $\frac{3}{4}$ " per 10'?

- A. $4 \frac{7}{8}$ "
- B. $5 \frac{5}{8}$ "
- C. $6 \frac{3}{8}$ "
- D. $7 \frac{1}{2}$ "

14. What is the pressure on test plug at the base of a 32' high stack when it is filled with water?

- A. 10.42 psi
- B. 13.89 psi
- C. 18.23 psi
- D. 62.50 psi

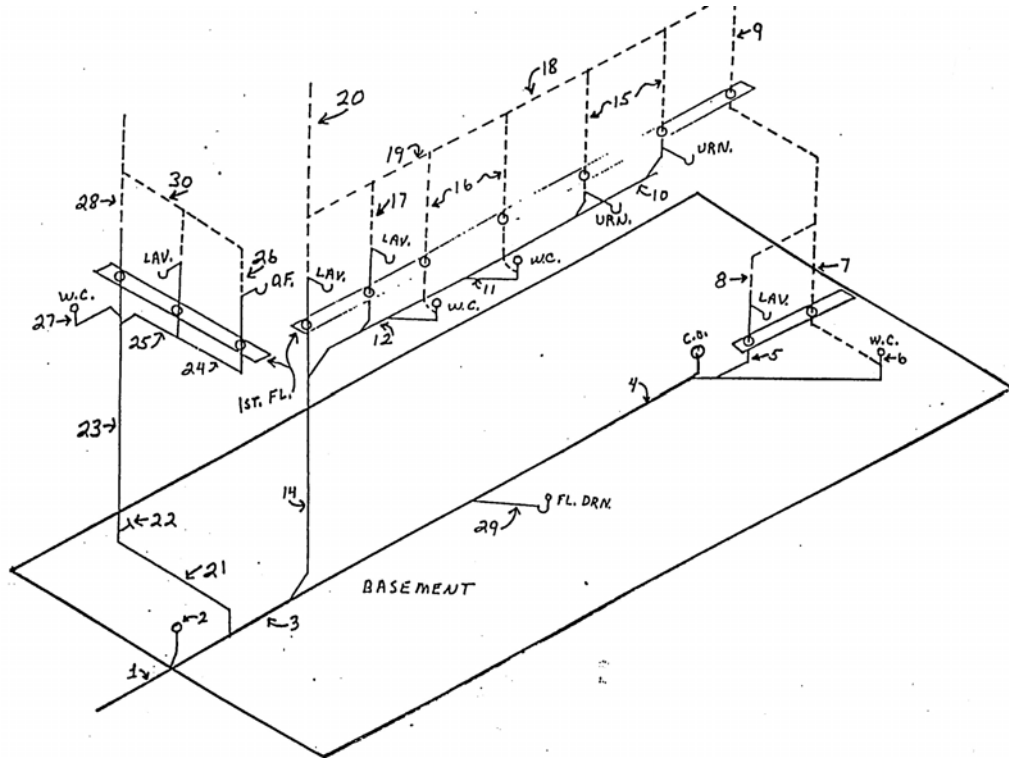

15. Which of these accurately describes the drinking fountain in the above diagram?
- A. It is individually vented.
 - B. It is crown vented.
 - C. It is stack vented.
 - D. It is not vented.
16. What should happen after a combination thermostat and EOC opens in an electric water heater?
- A. The thermostat should reset itself automatically.
 - B. The heating elements must be recalibrated.
 - C. The combined unit must be reset manually.
 - D. The EOC must be replaced immediately.
17. Which of these is **LEAST** likely to cause a submersible pump to deliver little or no water while it operates?
- A. Worn pump parts
 - B. A loose motor shaft
 - C. Defective motor wiring or cable
 - D. A pump intake screen blocked by mud or sand

Question 18 refers to the following diagram.

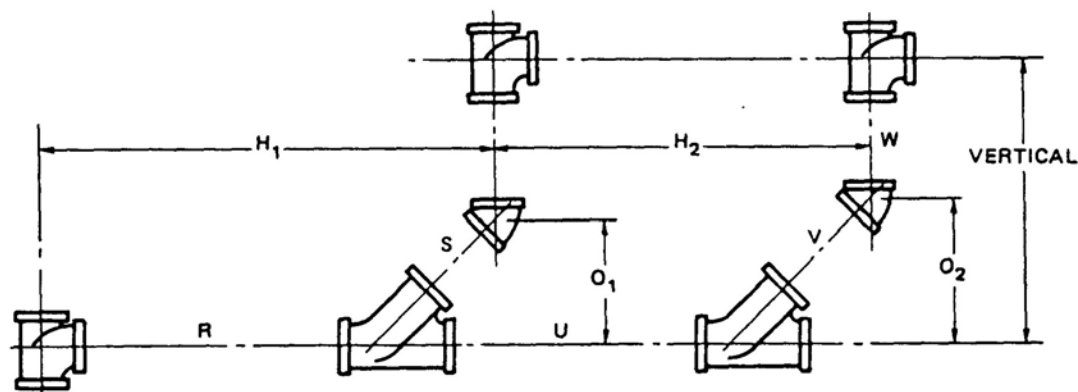

18. What is the end to end length of pipe W if H_1 measures $4'-7\frac{1}{2}"$, H_2 is $3'-4"$, the vertical measure is $5'-11\frac{1}{2}"$, and each offset is $10"$ for an assembly using $2"$ threaded pipe?

- A. $4'-7\frac{1}{2}"$
- B. $4'-6\frac{1}{2}"$
- C. $4'-8\frac{3}{4}"$
- D. $4'-9\frac{3}{4}"$

Correct Answers and References

Question	Correct Answer	References (See list on page 3 of this study guide)
1	C	Blankenbaker page 37, Ripka (1994) page 19
2	D	Blankenbaker pages 48-49, Smith pages 9, 168, 172 $2500' = 30,000"$; $Vol = (30,000" \times 3^2 \times \Pi) / 231$ cu in/gal = 3670 gallons
3	B	Blankenbaker pages 34-35
4	A	2002 Chicago Building Code 18-29-601.2 & 601.3
5	D	2002 Chicago Building Code 18-29-605.14.3
6	B	2002 Chicago Building Code 18-29-202
7	A	2002 Chicago Building Code 18-29-1111.3
8	D	2002 Chicago Building Code 18-29-906.1
9	A	2002 Chicago Building Code 18-29-1003.3.6 & 1003.3.3
10	C	2002 Chicago Building Code 13-200-420
11	D	Ripka (1994) pages 264-80, Guest pages 137-151
12	B	Blankenbaker pages 108-109
13	B	Smith pages 118-120; $.75" \times 75'/10' = .75" \times 7.5 = 5.625" = 5\frac{5}{8}"$
14	B	Smith page 178; 32×0.434 psi = 13.89 psi
15	A	Blankenbaker pages 123-127; Ripka (1994) pages 138-142
16	C	McConnell page 18
17	C	McConnell pages 147-150
18	D	Smith pages 79-85, 218, 223, 234; $W: c-c = 71\frac{1}{2}" - 10" = 61\frac{1}{2}"$ $e-e = 61\frac{1}{2}" - [(1\frac{11}{16} + 3\frac{1}{16}) - 2(\frac{1}{2})] = 61\frac{1}{2}" - 3\frac{3}{4}" = 57\frac{3}{4}" = 4'9\frac{3}{4}"$